

LIST OF KIT ELEMENTS

LOVA Power

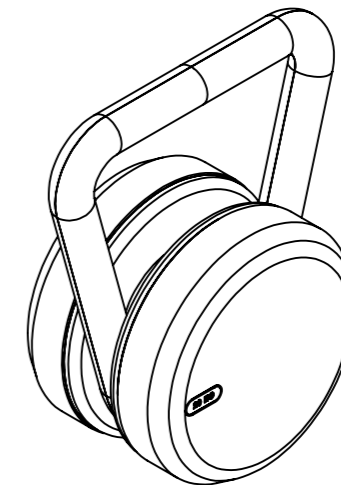

STEP 1

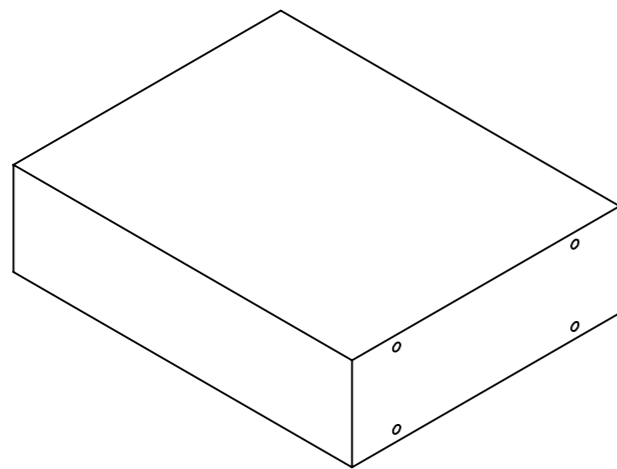
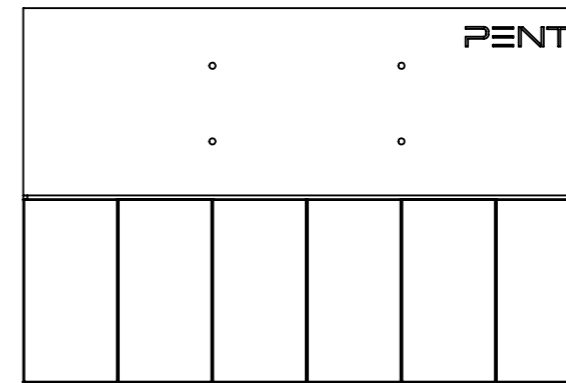
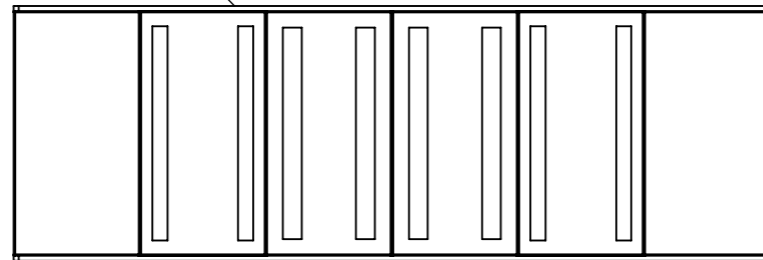
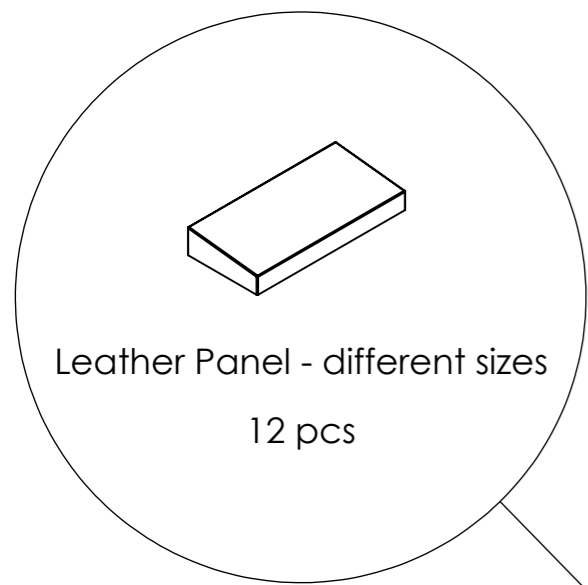
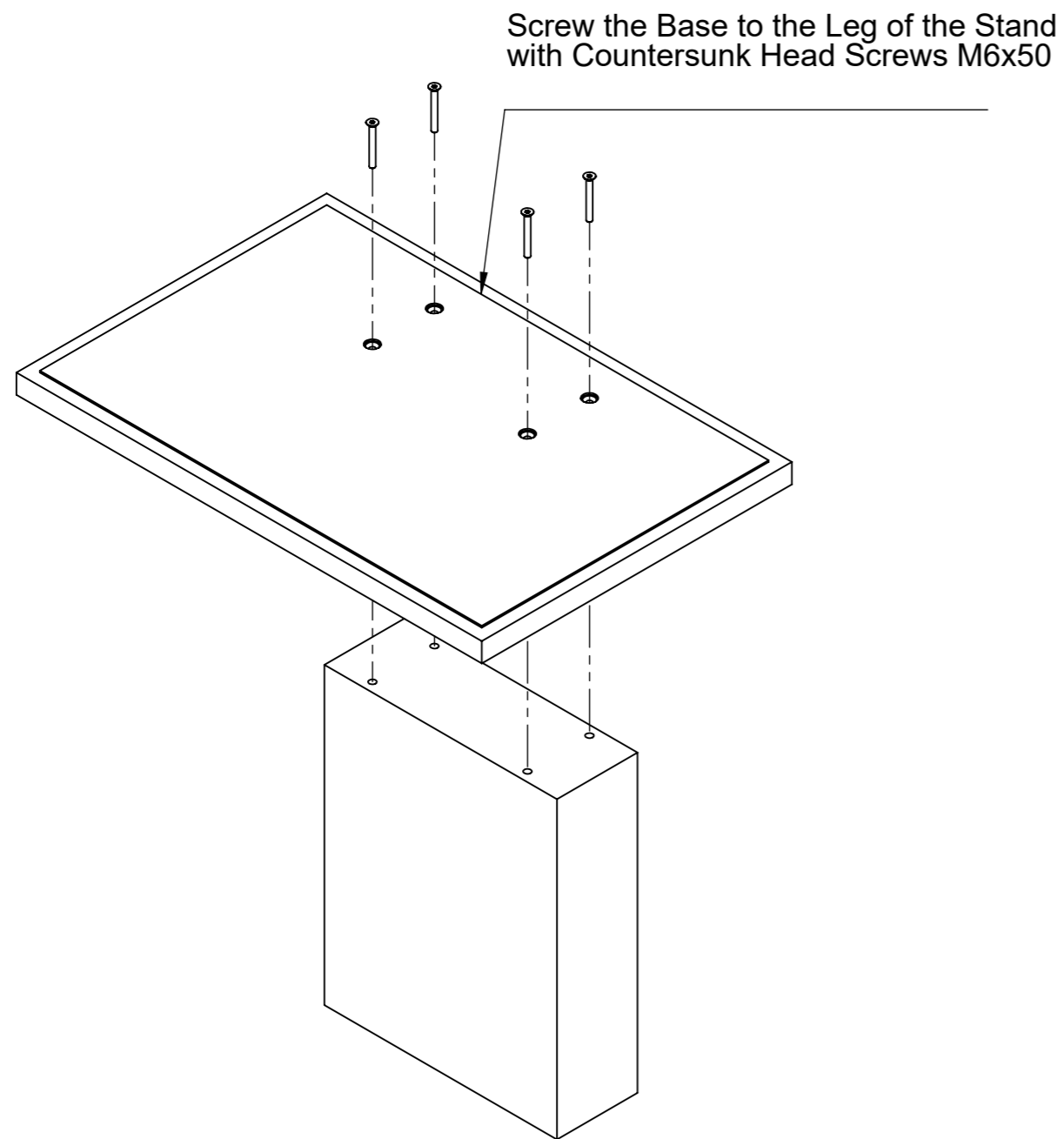

STEP 2

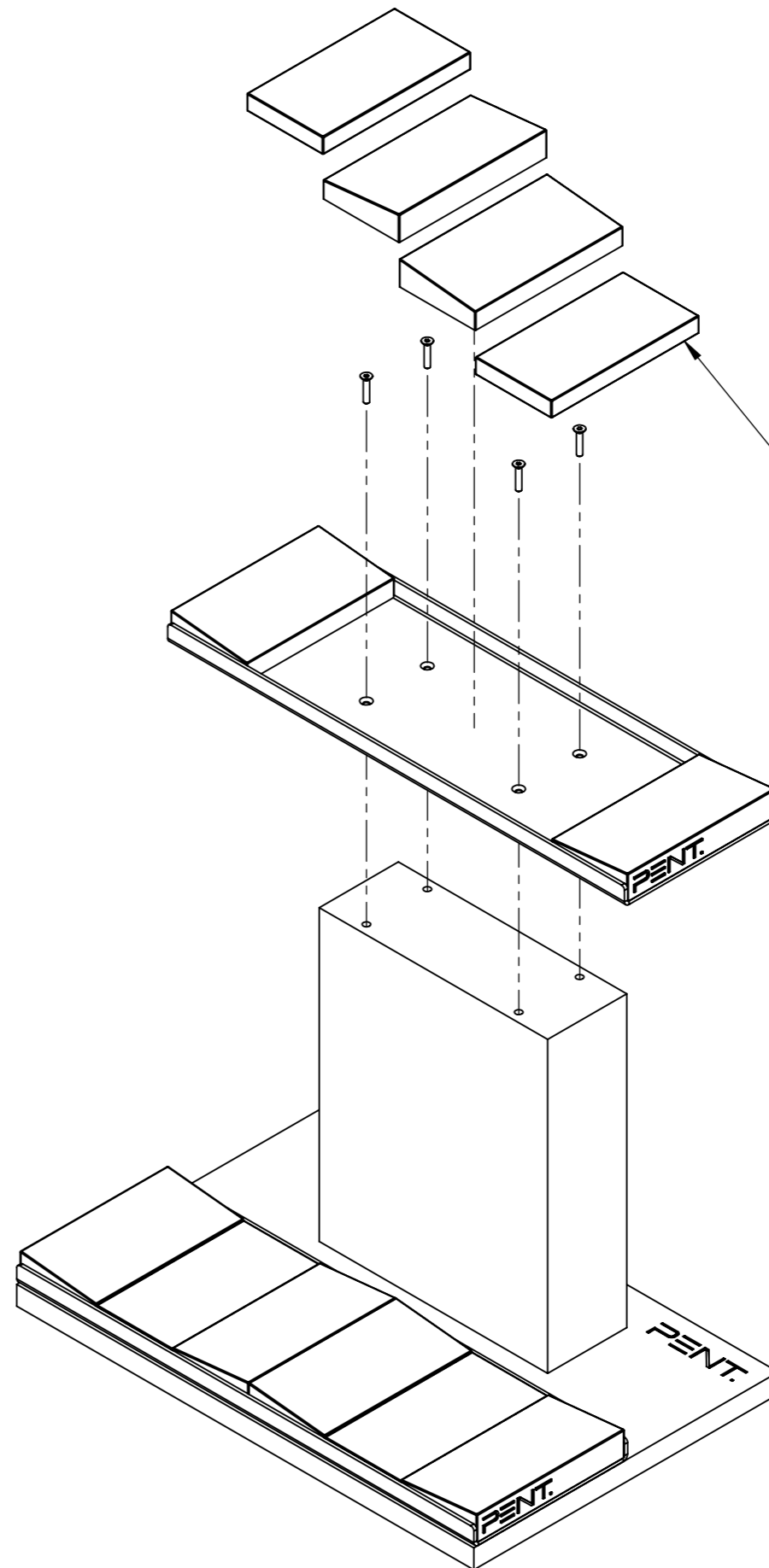

The Stand is delivered with Leather Panels already on it.

Top Shelf mounting holes are located under the Leather Panels placed upside down on the Top Shelf.

The Leather Panels placed upside down need to be removed.

Screw the Top and with Countersunk Screws M6x25, then place the removed Leather Panels in the right places on the Shelf.

STEP 3

Place the Dumbbells on the Leather Panels.

Place the Dumbbells from the lightest on the Top Stand Shelf, to the heaviest on the Bottom Stand Shelf

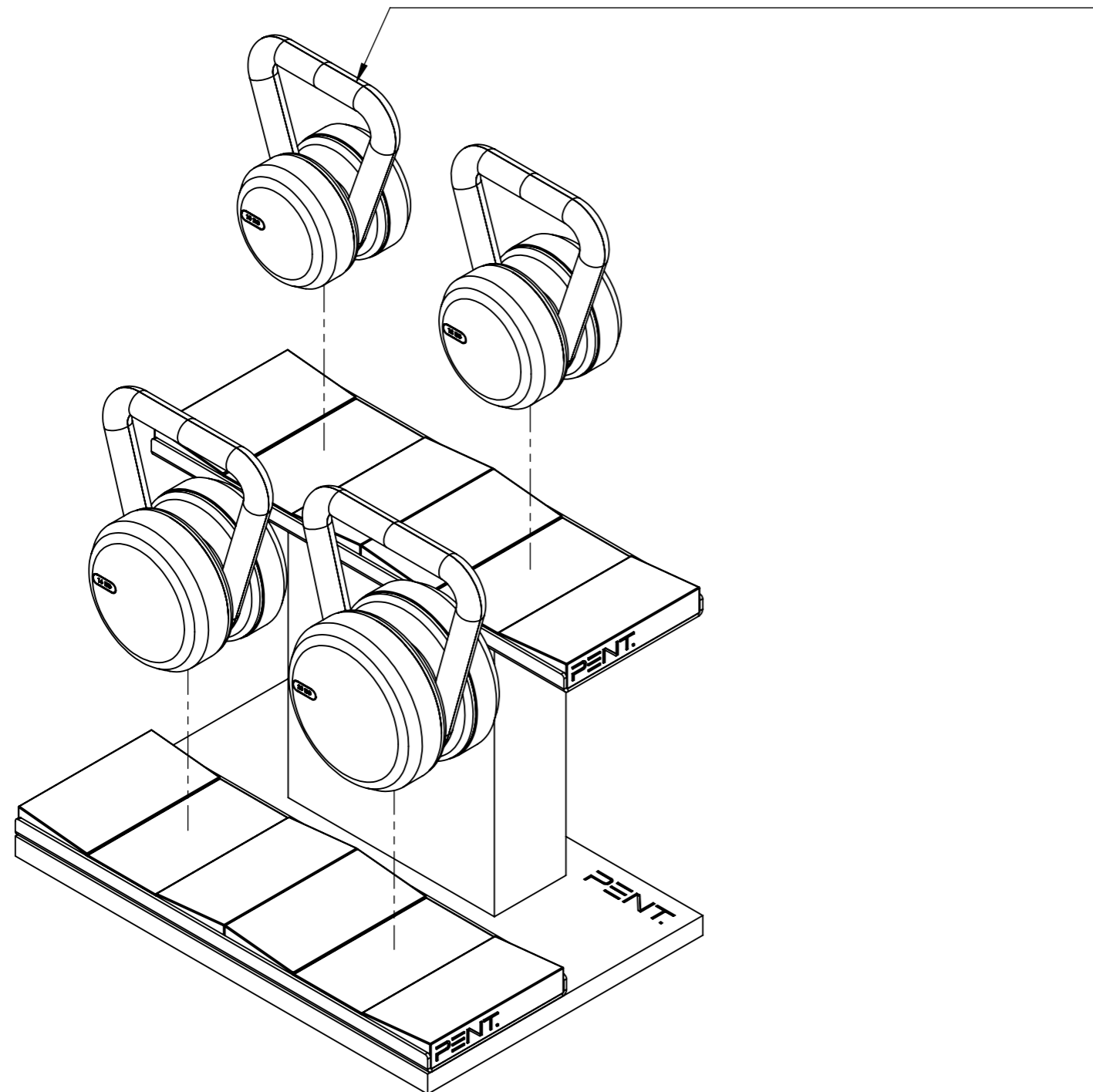

FINISHED ASSEMBLY

